

# LWO-AOC-SFP28-xxM

## 25Gbit SFP28 AOC Active Optical Cable

### Features

- Compliant with SFF-8472, SFF-8431, SFF-8432 and IEEE802.3by 25GBASESR
- Up to 25.78125Gb/s data rate
- Built-in digital diagnostic functions
- 850nm VCSEL transmitter and PIN receiver
- Single +3.3V power supply
- Maximum power dissipation 1W
- Operation case temperature: 0 to 70°C
- Maximum link length of 70m on OM3 MMF and 100m on OM4 MMF
- RoHS compliant

### Application

- 25G Ethernet
- InfiniBand & Fiber channel
- Switches, Routers, and HBAs
- Enterprise & Data Center
- Networking & Storage
- High Performance Computing Clusters



### General Description

The LWO-AOC-SFP28xx series constitutes a range of SFP28 active optical cables (AOCs) specifically engineered for 25 Gigabit Ethernet (25GbE) networking applications. These 25G SFP28 AOC cables serve as an optimal alternative to SFP28 direct-attach copper cables (DAC) and short-reach SFP28 transceivers, simultaneously delivering enhanced signal integrity and superior cost-performance ratios. Their design emphasizes high data transmission speeds, high port density, and minimal power requirements to address contemporary demands in data center infrastructure. Each AOC integrates SFP28 optical transceivers at each end coupled with OM3 multimode fiber cables available in lengths ranging from 1 to 100 meters. Additionally, they incorporate digital diagnostic capabilities accessible through a 2-wire serial interface as outlined in the SFF-8472 specification. All functional parameters maintain strict adherence to industry-standard protocols while optimizing operational efficiency across diverse deployment scenarios.

### Pin Assignment and Description

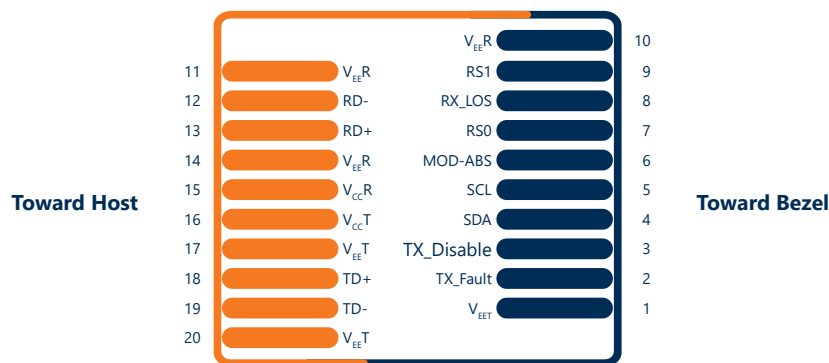

Figure 1. MSA Compliant Connector

### PIN Definition

PIN	Logic	Symbol	Name/Description	Notes
1		$V_{EE\ T}$	Transmitter Ground (Common with Receiver Ground)	1
2	LVTTL-O	$TX_{\text{FAULT}}$	Transmitter Fault	2
3	LVTTL-I	$TX_{\text{DISABLE}}$	Transmitter Disable. Laser output disabled on high or open	3
4	LVTTL-I/O	SDA	2-wire Serial Interface Data Line	4

## LWO-AOC-SFP28-xxM

### 25GBit SFP28 AOC Active Optical Cable

5	LVTTL-I/O	SCL	2-wire Serial Interface Clock Line	4
6		MOD_ABS	Module Absent. Grounded within the module	4
7	LVTTL-I	RS0	Rate Select 0, internal pull down	5
8	LVTTL-O	LOS	Loss of Signal indication. Logic 0 indicates normal operation.	6
9	LVTTL-I	RS1	Rate Select 1, internal pull down	5
10		V <sub>EE</sub> R	Receiver Ground (Common with Transmitter Ground)	1
11		V <sub>EE</sub> R	Receiver Ground (Common with Transmitter Ground)	1
12	CML-O	RD-	Receiver Inverted DATA out. AC Coupled	
13	CML-O	RD+	Receiver Non-inverted DATA out. AC Coupled	
14		V <sub>EE</sub> R	Receiver Ground (Common with Transmitter Ground)	1
15		V <sub>CC</sub> R	Receiver Power Supply	
16		V <sub>CC</sub> T	Transmitter Power Supply	
17		V <sub>EE</sub> T	Transmitter Ground (Common with Receiver Ground)	1
18	CML-I	TD+	Transmitter Non-Inverted DATA in. AC Coupled.	
19	CML-I	TD-	Transmitter Inverted DATA in. AC Coupled	
20		V <sub>EE</sub> T	Transmitter Ground (Common with Receiver Ground)	1

#### Notes

1. Circuit ground is internally isolated from chassis ground.
2. TFAULT is an open collector/drain output, which should be pulled up with a 4.7kΩ-10kΩ resistor on the host board if intended for use. Pull up voltage should be between 2.0V to Vcc + 0.3V. A high output indicates a transmitter fault caused by either the TX bias current or the TX output power exceeding the preset alarm thresholds. A low output indicates normal operation. In the low state, the output is pulled to <0.8V.
3. Laser output disabled on TDIS >2.0V or open, enabled on TDIS <0.8V.
4. Should be pulled up with 4.7kΩ-10kΩ on host board to a voltage between 2.0V and 3.6V. MOD\_ABS pulls line low to indicate module is plugged in.
5. Internally pulled down per SFF-8431 Rev 4.1.
6. LOS is open collector output. It should be pulled up with 4.7kΩ-10kΩ on host board to a voltage between 2.0V and 3.6V. Logic 0 indicates normal operation; logic 1 indicates loss of signal.

#### Host Board Power Supply Filtering

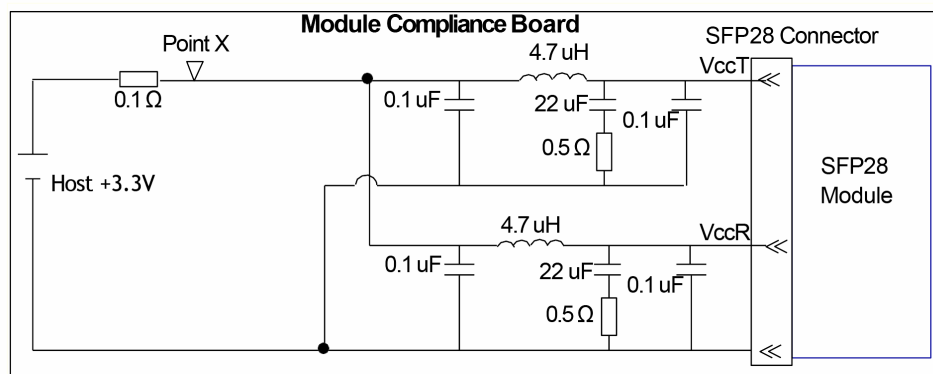

Figure 2: Module Compliance Board Power Supply Filters

## LWO-AOC-SFP28-xxM

### 25GBit SFP28 AOC Active Optical Cable

#### Absolute Maximum Ratings

It has to be noted that the operation in excess of any individual absolute maximum ratings might cause permanent damage to this module.

Parameter	Symbol	Min.	Max.	Units	Notes
Storage Temperature	TS	-40.0	85	degC	
Power Supply Voltage	V <sub>CC</sub>	-0.5	3.6	V	
Relative Humidity (non- condensation)	RH	5	85	%	

#### Recommended Operating Conditions and Power Supply Requirements

Parameter	Symbol	Min.	Typical	Max.	Units	Notes
Operating Case Temperature	T <sub>OP</sub>	0		70	degC	
Power Supply Voltage	V <sub>CC</sub>	3.135	3.3	3.465	V	
Data Rate, each Lane			25.78125		Gbps	
Power Consumption per termina		-		1	W	
Bit Error Ratio				1x10 <sup>-12</sup>		1

#### Notes

1. PRBS2<sup>^</sup>31-1@10.3125Gbps

#### Electrical Characteristics

The following electrical characteristics are defined over the Recommended Operating Environment unless otherwise specified.

Parameter		Unit	Min.	Typical	Max.	Notes
<b>Transceiver</b>						
Data Input Swing Differential		mV	200	-	1000	
Date Differential Impedance		Ω	90	100	110	
ModSelL	Module Select	V	V <sub>EE</sub> -0.3	-	0.4	
	Module Unselect	V	2	-	VCC+0.3	
LPMode	Low Power Mode	V	V <sub>EE</sub> -0.3	-	0.8	
	Normal Operation	V	2	-	VCC+0.3	
ResetL	Reset	V	V <sub>EE</sub> -0.3	-	0.8	
	Normal Operation	V	2	-	VCC+0.3	
<b>Receiver</b>						
Data Output Swing Differential		mV	200	-	1000	
Date Differential Impedance		Ω	90	100	110	
ModPrsL	Normal Operation	V	V <sub>EE</sub> -0.3	-	0.4	
IntL	Interrupt	V	V <sub>EE</sub> -0.3	-	0.4	
	Normal Operation	V	2	-	VCC+0.3	

# LWO-AOC-SFP28-xxM

## 25GBit SFP28 AOC Active Optical Cable

### Mechanical Dimensions

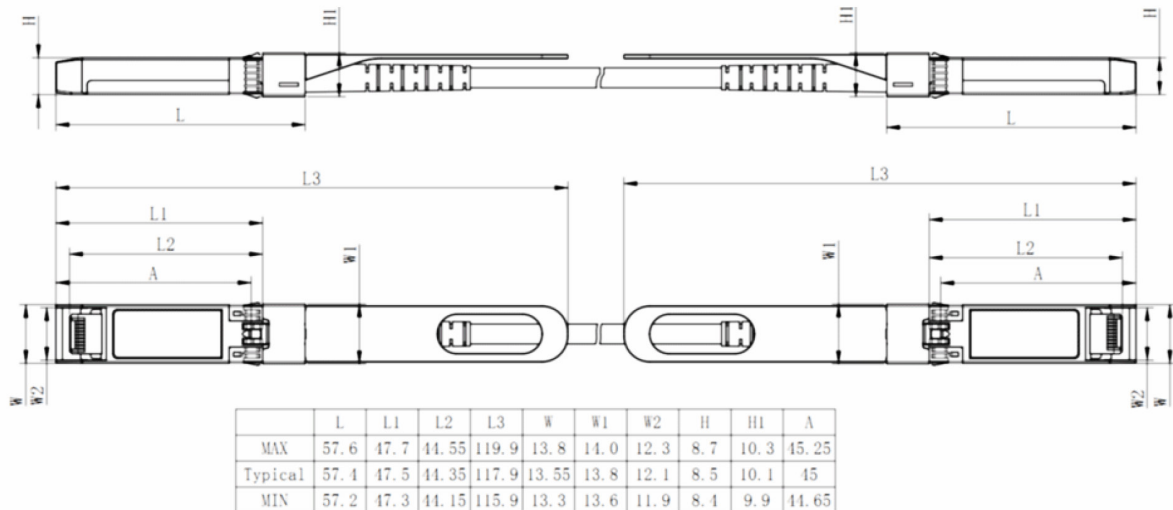

Figure 3. Mechanical Outline

### ESD

This transceiver is specified as ESD threshold 1kV for high speed data pins and 2kV for all others electrical input pins, tested per MIL-STD-883, Method 3015.4 /JESD22- A114-A (HBM). However, normal ESD precautions are still required during the handling of this module. This transceiver is shipped in ESD protective packaging. It should be removed from the packaging and handled only in an ESD protected environment.

### Laser Safety

This is a Class 1M Laser Product according to EN 60825-1:2014. This product complies with 21 CFR 1040.10 except for deviations pursuant to Laser Notice No. 50, dated (June 24, 2007).

Caution: Use of controls or adjustments or performance of procedures other than those specified herein may result in hazardous radiation exposure.

### Ordering Information

Part Number	Cable length
LWO-AOC-SFP28-5M	5 Meter
LWO-AOC-SFP28-10M	10 Meter
LWO-AOC-SFP28-20M	20 Meter
LWO-AOC-SFP28-30M	30 Meter