

## LWO-DAC-SFP28-xxM

### 25Gbit SFP28 to SFP28 Direct Attach Cable

#### Features

- Up to 25.78125 Gbps data rate
- Up to 5-meter transmission
- Hot-pluggable SFP 20PIN footprint
- Improved Pluggable Form Factor(IPF)
- Compliant for enhanced EMI/EMC performance
- Compatible to SFP28 MSA
- Temperature Range: 0 ~ 70 °C
- RoHS Compatible

#### Application

- 25G Ethernet



#### General Description

The objective is to provide SFP28 cable assemblies. This specification applies to the 1X size configurations. All materials and compounds used, meet the material restrictions of RoHS, (European Directive 2002/95/EC on the Restrictions of Hazardous Substances) as proposed by the RoHS Technical Adaptation Committee.

This specification is applicable to SFP28 external connector system which provides a high-speed cable to board interconnect.

Lightwin's Small Form-factor Pluggable solution achieving 25G transmission (hereafter referred to as SFP28) is designed for high-density applications. The hot-pluggable transceiver integrates 1 transmitting and 1 receiving channels.

Lightwin's SFP28 cable assemblies are high performance, high bandwidth and cost-effective interconnect solutions which support 25G standards with different data rate applications.

#### Reference Documents

The following documents are forming a part of this specification to the extent specified.

- SFF8074: SFP Small Form-Factor Pluggable Transceiver Rev 1.0
- SFF8431: Specification for Enhanced SFF Pluggable Module SFP+
- SFF8432: Improved Pluggable Form Factor
- SFF8402 SFP+ 28Gb/s 1x Pluggable Transceiver Solution
- SFF8472: Diagnostic Monitoring Interface for Optical Transceivers
- SFF 8417: Multi Conductor Cable Flex Cycle Test Procedure
- IEEE 802.3bj: IEEE standard for Ethernet
- IEEE 802.3by Media Access Control Parameters, Physical Layers, and Management Parameters for 25 Gb/s Operation

#### Absolute Maximum Ratings

Parameter	Symbol	Unit	Min.	Max.
Storage Temperature Range	TS	°C	-40	+85
Relative Humidity	RH	%	5	85
Power Supply Voltage	V <sub>CC</sub>	V	3.135	+3.465
Operating Case Temperature Range	T <sub>C</sub>	°C	0	+70

# LWO-DAC-SFP28-xxM

## 25GBit SFP28 to SFP28 Direct Attach Cable

### Pin Assignment and Description

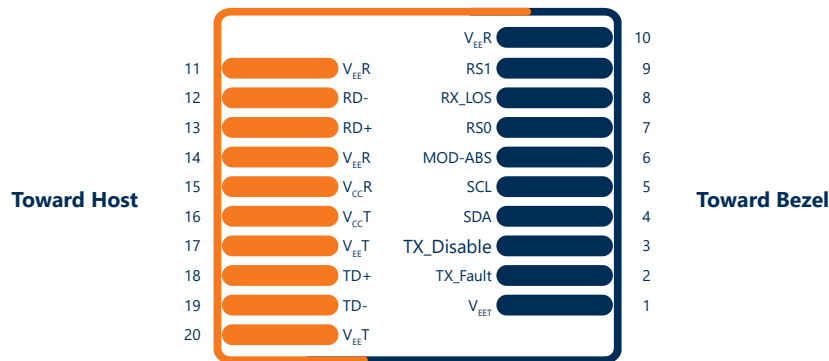

Figure 1: SFP28 module pad layout

Pair No.	P1		P2	
	Pin	Signal	Pin	Signal
1	20	GND	11	GND
	19	TX1n	12	RX1n
	18	TX1p	13	RX1p
	17	GND	14	GND
2	11	GND	20	GND
	12	RX1n	19	TX1n
	13	RX1p	18	TX1p
	14	GNS	17	GND

Table 1: Wire connection

### Performance Requirements

Test Items	Test Condition	Specification
Current		0.5A per contact
Voltage		30 vDC per contact
LLCR	EIA 364-23, 20mVdc, 100mA	less than 2 ohms
Insulation Resistance	100 Vdc	10 Mohms minimum between adjacent contacts
Dielectric Withstanding Voltage	300 VDC minimum for 1 minutes	No defect or breakdown between adjacent contacts
Temperature Rise	Measure the temperature rise at the rated current after 96 hours(45 minutes ON/15 minutes OFF per hour).	Temperature rise: +30°C MAX.
Continuity	Verify the continuous electrical path	No open, short, or high resistance.

### SI Requirements

Test Items	Specification	Notes
SDD21&SDD12	-22.48 dB Min. @12.89GHz	From 0.01 GHz-19GHz
SDD11&SDD22	<ul style="list-style-type: none"> <li>-16.5+2*sqrt(f)dB Max. @0.05GHz~4.1GHz</li> <li>-10.66+14*log(f/5.5)dB Max. @4.1GHz~10GHz</li> </ul>	From 0.01 GHz-19GHz
SCD21-SDD21	<ul style="list-style-type: none"> <li>-10 dB Max. @0.01 GHz~12.89 GHz</li> <li>-27+(29/22)*f dB Max. @12.89 GHz~15.7 GHz</li> <li>-6.3 dB Max. @15.7 GHz~19 GHz</li> </ul>	From 0.01 GHz-19GHz

## LWO-DAC-SFP28-xxM

### 25GBit SFP28 to SFP28 Direct Attach Cable

#### Mechanical Performance Requirements

Test Items	Test Condition	Specification
Mating Forces	A rate of 10mm per minute	SFP<18N
Un-mating Forces	A rate of 10mm per minute	SFP<12.5N
Latch strength	Pull to separate module from cage, Test with connector, cage & module (latch engaged)	SFP<90N force
Bulk cable retention in module	Pull to separate bulk cable from module, Test with cable assembly only	Minimum of an 90N force
Wire Flex	Flex cable 180° for 10 cycles at X/Y axis, 20 times/minutes, with an 1kg suspended weight. Type C EIA 364-41, test condition I.	No microsecond discontinuities are allowed.
Durability	Perform 50 unplug/plug cycles	No evidence of physical damage
Cable Minimum Bend Radius	Min. bending radius allowed : repeated 10X $\varnothing$ . single 5X $\varnothing$	1. No physical damage 2. Verify continuity and SI

#### Design and construction

##### Connector

The connector meets the various dimensional and physical requirements outlined in the SFF-8432 specification

##### Cable

Cable type is a 100 ohm twinax cable which consists of 2 parallel pairs. Printing on the cable is defined in the respective cable specification. Each pair consists of two signal conductors and two drains wire wrapped in a shield.



Figure 2: Cable

#### Cable Assembly

Cable Bulk shield is directly to be connected to the connector backshell to minimize EMI. Each cable assembly is labelled with a unique identification label.

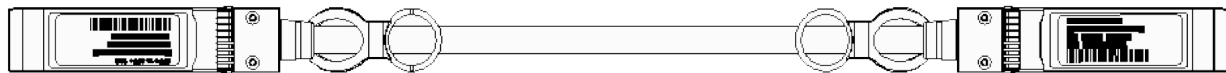

Figure 3: Cable Assembly

## LWO-DAC-SFP28-xxM

### 25GBit SFP28 to SFP28 Direct Attach Cable

#### Mechanical Dimensions

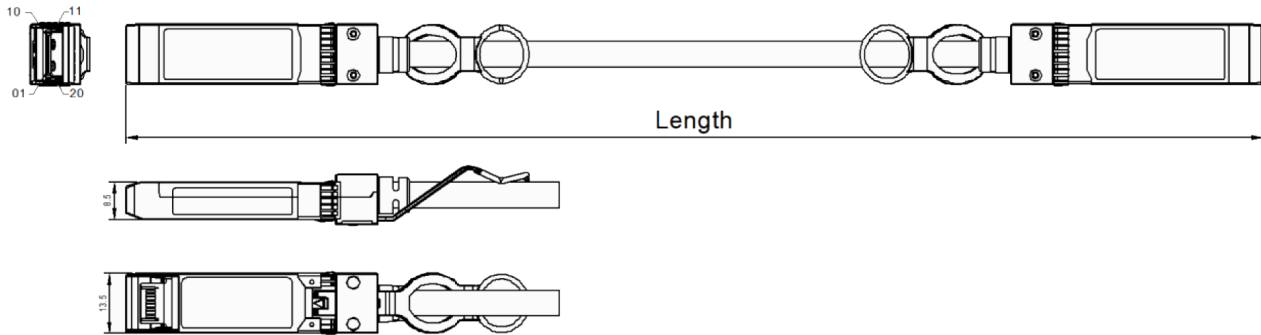

Figure 4. Mechanical Outline

#### ESD

This transceiver is specified as ESD threshold 1kV for high-speed data pins and 2kV for all others electrical input pins, tested per MIL-STD-883, Method 3015.4 /JESD22- A114-A (HBM). However, normal ESD precautions are still required during the handling of this module. This transceiver is shipped in ESD protective packaging. It should be removed from the packaging and handled only in an ESD protected environment.

#### Ordering Information

Part Number	Cable length
LWO-DAC-SFP28-0.5M	0.5 Meter
LWO-DAC-SFP28-1M	1.0 Meter
LWO-DAC-SFP28-3M	3.0 Meter
LWO-DAC-SFP28-5M	5.0 Meter