

LWO-SFPP-2733-60

10 Gbit SFP+ BiDi, 1270nmTX/1330nmRX, 60km, DDM, LC-Simplex, Singlemode

Features

- Up to 11.3Gb/s data links
- 1270nm DFB laser and APD receiver for IT010SPB2760
- 1330nm DFB laser and APD receiver for IT010SPB3360
- Up to 60km on 9/125µm SMF
- Hot-pluggable SFP+ footprint
- Duplex LC/UPC type pluggable optical interface
- RoHS compliant and lead-free
- Support Digital Monitoring interface
- Single +3.3V power supply
- Compliant with SFF+MSA and SFF-8472
- Metal enclosure, for lower EMI
- Meet ESD requirements, resist 8KV direct contact voltage
- Case operating temperature
- Commercial: 0 ~ +70°C
- Industrial: -40 ~ +85°C

Application

- 10GBASE-ER/EW & 10G Ethernet
- SDH STM64
- Other Optical Links

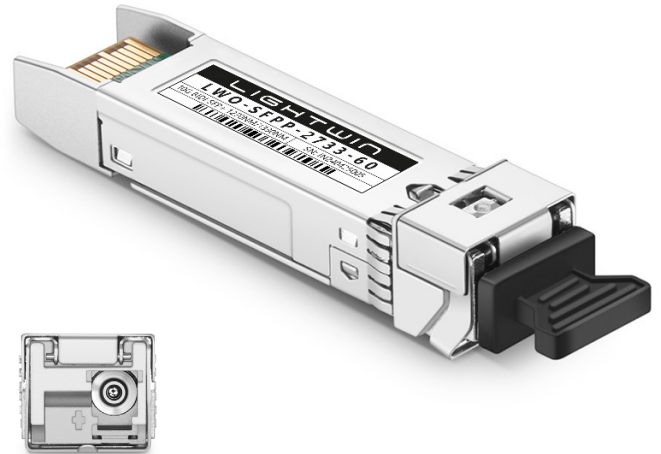

General Description

Lighwin Optic's SFP+ transceiver is designed for use in 10-Gigabit Ethernet links up to 60km over single mode fiber. The module consists of CWDM DFB Laser, APD and Preamplifier in a high-integrated optical sub-assembly. Digital diagnostics functions are available via a 2-wire serial interface, as specified in SFF-8472.

The transceivers provide a unique enhanced digital diagnostic monitoring interface, which allows real-time access to device operating parameters such as transceiver temperature, laser bias current, transmitted optical power, and received optical power and transceiver supply voltage. It also defines a sophisticated system of alarm and warning flags, which alerts end-users when particular operating parameters are outside of a factory set normal range.

The SFP+ MSA defines a 256-byte memory map in EEPROM that is accessible over a 2-wire serial interface at the 8bit address 1010000X (A0h). The digital diagnostic monitoring interface makes use of the 8bit address 1010001X (A2h), so the originally defined serial ID memory map remains unchanged.

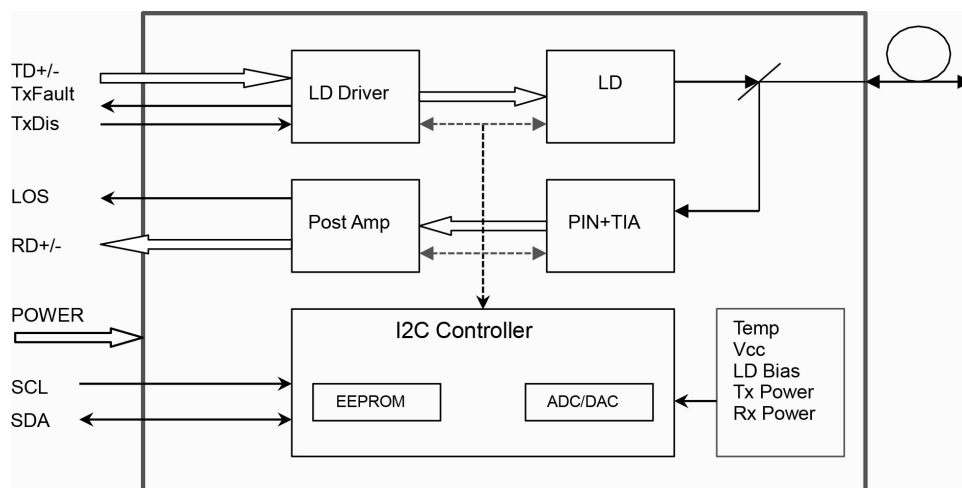

Figure 1. Transceiver functional diagram

LWO-SFPP-2733-60

10 Gbit SFP+ BiDi, 1270nmTX/1330nmRX, 60km, DDM, LC-Simplex, Singlemode

Absolute Maximum Ratings

It has to be noted that the operation in excess of any individual absolute maximum ratings might cause permanent damage to this module.

Parameter	Symbol	Min	Max.	Unit	Notes
Storage Temperature	T_s	-40	+85	°C	
Power Supply Voltage	V _{CC}	-0.5	+3.6	V	
Relative Humidity (non-condensation)	R _H	5	95	%	
Damage Threshold	TH _d	5		dBm	

Recommended Operating Conditions and Power Supply Requirements

Parameter	Symbol	Min	Typical	Max.	Unit	Notes
Operating Case Temperature	T _{OP}	0		70	°C	commercial
		-40		85		industrial
Power Supply Voltage	V _{CC}	3.135	3.3	3.465	V	
Data Rate			10.3125		Gb/s	
Control Input Voltage High		2		V _{CC}	V	
Control Input Voltage Low		0		0.8	V	
Link Distance (SMF)	D			60	km	9/125 μm

Pin Assignment and Description

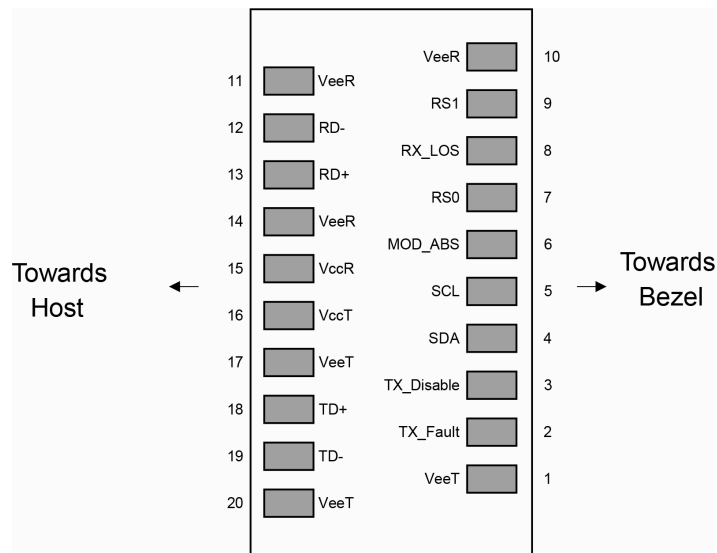

Figure 2. MSA Compliant Connector

LWO-SFPP-2733-60

10 Gbit SFP+ BiDi, 1270nmTX/1330nmRX, 60km, DDM, LC-Simplex, Singlemode

Pin Definition

Pins	Logic	Symbol	Name/Description	NOTE
1		VeeT	Transmitter Ground (Common with Receiver Ground)	1
2	LVTTTL-O	TX_Fault	Transmitter Fault.	2
3	LVTTTL-I	TX_Disable	Transmitter Disable. Laser output disabled on high or open.	3
4	LVTTTL-I/O	SDA	2-wire Serial Interface Data Line	4
5	LVTTTL-I/O	SCL	2-wire Serial Interface Clock Line	4
6		MOD_ABS	Module Absent. Grounded within the module	4
7	LVTTTL-I	RS0	Rate Select 0, internal pull down	5
8	LVTTTL-O	LOS	Loss of Signal indication. Logic 0 indicates normal operation.	6
9	LVTTTL-I	RS1	Rate Select 1, internal pull down	5
10		VeeR	Receiver Ground (Common with Transmitter Ground)	1
11		VeeR	Receiver Ground (Common with Transmitter Ground)	1
12	CML-O	RD-	Receiver Inverted DATA out. AC Coupled	
13	CML-O	RD+	Receiver Non-inverted DATA out. AC Coupled	
14		VeeR	Receiver Ground (Common with Transmitter Ground)	1
15		VccR	Receiver Power Supply	
16		VccT	Transmitter Power Supply	
17		VeeT	Transmitter Ground (Common with Receiver Ground)	1
18	CML-I	TD+	Transmitter Non-Inverted DATA in. AC Coupled.	
19	CML-I	TD-	Transmitter Inverted DATA in. AC Coupled.	
20		VeeT	Transmitter Ground (Common with Receiver Ground)	1

Notes:

1. Circuit ground is internally isolated from chassis ground.
2. TFAULT is an open collector/drain output, which should be pulled up with a 4.7kΩ-10kΩ resistor on the host board if intended for use. Pull up voltage should be between 2.0V to Vcc + 0.3V. A high output indicates a transmitter fault caused by either the TX bias current or the TX output power exceeding the preset alarm thresholds. A low output indicates normal operation. In the low state, the output is pulled to <0.8V.
3. Laser output disabled on TDIS >2.0V or open, enabled on TDIS <0.8V.
4. Should be pulled up with 4.7kΩ-10kΩ on host board to a voltage between 2.0V and 3.6V. MOD_ABS pulls line low to indicate module is plugged in.
5. Internally pulled down per SFF-8431 Rev 4.1.
6. LOS is open collector output. It should be pulled up with 4.7kΩ-10kΩ on host board to a voltage between 2.0V and 3.6V. Logic 0 indicates normal operation; logic 1 indicates loss of signal.

LWO-SFPP-2733-60

10 Gbit SFP+ BiDi, 1270nmTX/1330nmRX, 60km, DDM, LC-Simplex, Singlemode

Electrical Characteristics

The following electrical characteristics are defined over the Recommended Operating Environment unless otherwise specified. nent damage to this module.

Parameter	Symbol	Min.	Typ.	Max.	Unit	Notes
Power Consumption	P			1.5	W	
Supply Current	Icc			450	mA	
Transmitter						
Single-ended Input Voltage Tolerance	VCC	-0.3		4.0	V	
AC Common Mode Input Voltage Tolerance (RMS)		15			mV	
Differential Input Voltage Swing	V _{in} , pp	120		820	mV pp	
Differential Input Impedance	Z _{in}	90	000	110	Ohm	1
Transmit Disable Assert Time				10	us	
Transmit Disable Voltage	V _{dis}	V _{cc} -1.3		V _{cc}	V	
Transmit Enable Voltage	V _{en}	V _{ee}		V _{ee} +0.8	V	2
Receiver						
Differential Output Voltage Swing	V _{out} , pp	350		850	mV pp	
Differential Output Impedance	Z _{out}	90	100	110	Ohm	3
Data output rise/fall time	T _r /T _f	28			ps	4
LOS Assert Voltage	V _{losH}	V _{cc} -1.3		V _{ee} +0.8	V	5
LOS De-assert Voltage	V _{losL}	V _{ee}		V _{ee} +0.8	V	5
Power Supply Rejection	PSR	100			mV pp	6

Notes:

1. Connected directly to TX data input pins. AC coupled thereafter.
2. Or open circuit.
3. Input 100 ohms differential termination.
4. These are unfiltered 20-80% values.
5. Loss of Signal is LVTTTL. Logic 0 indicates normal operation; logic 1 indicates no signal detected.
6. Receiver sensitivity is compliant with power supply sinusoidal modulation of 20 Hz to 1.5 MHz up to specified value applied through the recommended power supply filtering network.

Optical Characteristics 1/2

The following optical characteristics are defined over the Recommended Operating Environment unless otherwise specified

Parameter	Symbol	Min.	Typ.	Max.	Units	Notes
Transmitter						
Center Wavelength	λ	1260	1270	1280	nm	LWO-SFPP-2733-60
		1320	1330	1340		LWO-SFPP-3327-60
Optical Spectral Width	$\Delta\lambda$			1	nm	
Side Mode Suppression Ratio	SMSR	30			dB	
Average Optical Power	P _{AVG}	0		5	dBm	
Extinction Ratio	ER	3.5			dB	
Transmitter and Dispersion Penalty	TDP			3.2	dB	
Transmitter OFF Output Power	P _{off}			-30	dBm	
Transmitter Eye Mask		Compliant with IEEE802.3ae				

LWO-SFPP-2733-60

10 Gbit SFP+ BiDi, 1270nmTX/1330nmRX, 60km, DDM, LC-Simplex, Singlemode

Optical Characteristics 2/2

Parameter	Symbol	Min.	Typ.	Max.	Units	Notes
Receiver						
Center Wavelength	λ_c	1320	1330	1340	nm	LWO-SFPP-2733-60
		1260	1270	1280		LWO-SFPP-3327-60
Sensitivity (Average Power)	Sen.			-20	dBm	1
Input Saturation Power (overload)	Psat	-8			dBm	
LOS Assert	LOSA	-35			dBm	
LOS De-assert	LOSD			-21	dBm	
LOS Hysteresis	LOSH	0.5			dB	

Notes:

1. Measured with Light source 1270nm @1330nm, ER=3.5dB; BER \leq 1E-12 @10.3125Gbps, PRBS=2³¹ -1 NRZ.

Digital Diagnostic Functions

The following digital diagnostic characteristics are defined over the Recommended Operating Environment unless otherwise specified. It is compliant to SFF-8472 Rev10.2 with internal calibration mode. For external calibration mode please contact our sales staff.

Parameter	Symbol	Min.	Max.	Unit	Notes
Temperature monitor absolute error	DMI_Temp	-3	3	°C	Over operating temp
Supply voltage monitor absolute error	DMI_VCC	-0.15	0.15	V	Full operating range
RX power monitor absolute error	DMI_RX	-3	3	dB	
Bias current monitor	DMI_bias	-10%	10%	mA	
TX power monitor absolute error	DMI_TX	-3	3	dB	

Mechanical Dimensions

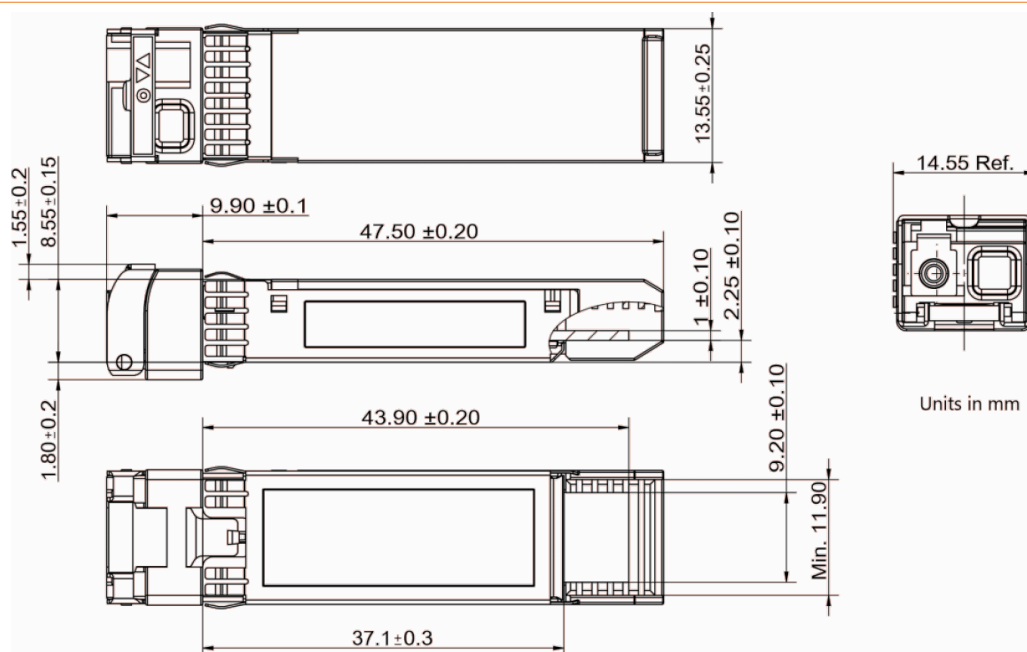

Figure 3. Mechanical Outline

LWO-SFPP-2733-60

10 Gbit SFP+ BiDi, 1270nmTX/1330nmRX, 60km, DDM, LC-Simplex, Singlemode

ESD

This transceiver is specified as ESD threshold 1kV for high speed data pins and 2kV for all other electrical input pins, tested per MIL-STD-883, Method 3015.4 / JESD22- A114-A (HBM). However, normal ESD precautions are still required during the handling of this module. This transceiver is shipped in ESD protective packaging. It should be removed from the packaging and handled only in an ESD protected environment.

Laser Safety

This is a Class 1 Laser Product according to EN 60825-1:2014. This product complies with 21 CFR 1040.10 and 1040.11 except for deviations pursuant to Laser Notice No. 50, dated (June 24, 2007).

Caution: Use of controls or adjustments or performance of procedures other than those specified herein may result in hazardous radiation exposure.

LWO-SFPP-2733-60

10 Gbit SFP+ BiDi, 1270nmTX/1330nmRX, 60km, DDM, LC-Simplex, Singlemode

LWO-SFPP-2733-60

10 Gbit SFP+ BiDi, 1270nmTX/1330nmRX, 60km, DDM, LC-Simplex, Singlemode

Recommended Application Circuit

